



2250JBT

TELESCOPIC CRANE SPECIFICATIONS



GENERAL SPECIFICATIONS

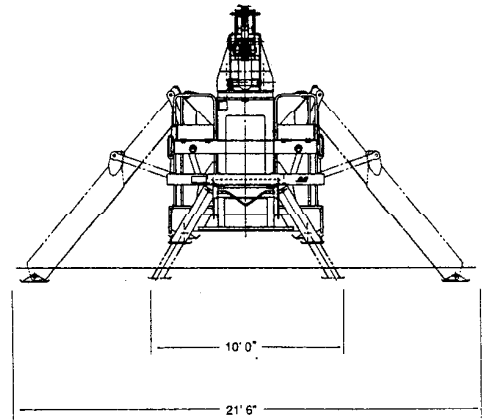
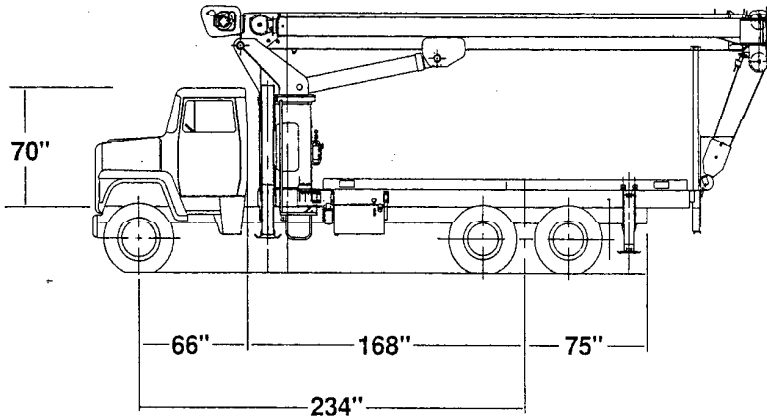

RECOMMENDED CHASSIS SPECIFICATIONS (180' Area Of Operation)	
DESCRIPTION	REC. DIM.
WHEEL BASE	234"
CAB to AXLE	168"
BACK of CAB to FRONT AXLE	66"
CAB HEIGHT ABOVE FRAME (Max.)	70"
AFTER FRAME REQUIRED	75"
FRONT AXLE WEIGHT RATING (Min.)	16,000 lbs.
REAR AXLE WEIGHT RATING (Min.)	34,000 lbs.
FRONT AXLE CURB WEIGHT (Min.)	7,600 lbs
REAR AXLE CURB WEIGHT (Min.)	7,500 lbs.
PAYLOAD WATER LEVEL LOADING (Approx.)	11,000 lbs.
FRAME 21 S.M.(Min.) ON 110,000 P.S.I. STEEL	
TOTAL CRANE WEIGHT w/18' WOOD DECK & STAB'S., LESS TRUCK CHASSIS - 20,250 LBS.	

TRUCK CHASSIS NOTES

- Weights do not include options.
- Distributor must submit a "Chassis Information Sheet" before receiving a quotation or JLG accepting a firm Purchase order.
- Trucks require an electric engine shut off in order for the console stop switch to be functional.
- Diesel engine with a mechanical governor also must have a variable speed governor.
- Horizontal exhaust with vertical muffler will require extensive exhaust modifications. A "Chassis Information Sheet" must be submitted before additional charges can be added. Exhaust modifications do not include parts. Refer to "Standards Relocation Charges".
- Automatic Transmissions must have a neutral lock-up. (Chassis manufacturer supplied).
- All chassis must meet minimum truck specifications for model and boom length. Refer to "Individual Truck Specifications Sheets".
- Some chassis equipped with Allison automatic and CAT diesel engines require a remote mounted pump with a drive shaft and clockwise rotation pump. Consult factory for installation charges.
- Trucks with longer wheel bases than those specified on the "Truck Specification Sheet" will require a higher FAWR (Front Axle Weight Rating) than is listed on the specification sheet. Consult factory for proper rating.
- If cab heights, as measured from the top of the truck frame to the top of the cab roof exceed 68.5 inches, consult factory for additional charges.
- Truck frames with heights greater than 40.4 inches will increase overall height of the mounted crane and will decrease outrigger and stabilizer ground penetration.
- Truck frames with heights less than 34 inches of width will require special brackets and chimo. Consult factory for additional installation charge.
- Trucks with air horns require an electrical horn. Consult factory for installation charge.
- Cranes utilizing the air throttle option will require a chassis air compressor.
- Special or heavy duty decks will increase weight on the rear axle, while reducing water level payload availability. "Chassis Information Sheets" must be submitted and approved before installation.
- Chassis engines that do not have manual throttle linkage will require additional charges. Consult factory.

JLG 2250JBT

STANDARD CRANE SPECIFICATIONS

RATING: 45,000 lbs. at 5 ft. load radius, 28,000 lbs. at 10 ft. load radius. Maximum load radius = 80 ft. Maximum horizontal reach = 80 ft. Maximum tip height = 95 ft.

ANTI-TWO BLOCK SYSTEM: Basic P. A. T. anti-two block system with complete function lockout of hoist up, telescope out and boom down crane functions.

MAIN BOOM: 26 ft. – 85 ft., four section, inverted top hat cross section design for maximum strength to weight ratio. Boom extension is fully proportional and is accomplished by a 5 1/2" bore, double action telescope cylinder with integral holding valve which extends the inner-mid section. Outer-mid and fly are simultaneously mechanically extended by 9/16" diameter cables attached to the inner and outer mid-section, which ensures proportional extensions of all boom lengths. Extension cables are supported by one, four groove 10 in. tread diameter non-metallic sheave which is attached to the barrel end of the telescope cylinder.

BOOM NOSE: Three non-metallic sheaves, 10 in. tread diameter, mounted on bronze bushings. Idler sheave is a floating sheave wheel. The boom nose also contains integral yoke shaft for future bucket installation. Each sheave wheel contains external grease fittings for ease of maintenance.

JIBS: Optional 26 ft. fixed length side stow, 26 ft – 46 ft., two section side stow and 21 ft. side stow that can be offset 0 degrees, 15 degrees, 30 degrees and 45 degrees. All jibs contain adjustable brackets for easy alignment during field installation.

BOOM ELEVATION: Single double acting 7 in. bore lift cylinder with integral holding valve provides elevation from -8 degrees to +80 degrees. Mechanical pendulum angle indicators are provided on both sides of boom.

HOIST: Layaway, planetary drive, power up and down two speed with automatic brake. Maximum single line speed 304 FPM. Maximum permissible line pull 7,500 lbs. Two speed is obtainable on the fly with no stopping of the hoist needed to engage two speed function.

SWING: Planetary drive, 375 degree non-continuous rotation. Equipped with spring applied, hydraulically released automatic multiple disc type brake. Swing bearing is bolted to the pedestal and turntable using 3/4 in. dia. grade 8 bolts which are lock tabbed in place after final torque. Maximum swing speed is 1.5 RPM.

PEDESTAL: All welded box type construction reinforced at critical points to ensure a rigid mount.

OUTRIGGER: A-frame type, 8 ft. retracted, 21 ft. 6 in. extended. Double acting hydraulic cylinders with integral holding valves on each extension cylinder. 11 in. by 17 in. pivoting steel pads that are flared on the leading and trailing edges. All attach pins are nickel plated and wear pads are nylatron.

STABILIZERS: A-frame type, 8 ft. retracted, 10 ft. extended. Double acting hydraulic cylinders with integral holding valves on each extension cylinder. 10-3/4 in. by 11-1/2 in. fixed pads that are flared on the leading and trailing edges. Wear pads are nylatron. Out and down stabilizers are optional.

TORSION BOX (sub-frame): Four plate with integral rib design, is torsionally resistant. Mounted under the crane pedestal it runs full length and is bolted directly to the truck frame. Bolts are in shear condition for maximum resistance to imposed external forces.

CONTROL STATIONS: Dual operator stations equipped with four single lever crane controls that are arranged to PCSA standards. Fully proportional control valves. Outrigger and stabilizer controls allow independent extension and retraction. Each station contains engine start/stop, mechanical foot throttles, warning horn and adjustable bubble levels. Load charts, range diagrams, jib charts and component deduction charts are mounted on pivoting plates directly in front of the operator.

HYDRAULIC SYSTEM: A three section gear pump is direct mounted to a power take-off on the truck transmission. Flow distribution is 39 GPM to the hoist function 24 GPM to the crane functions and 8 GPM to the swing function. A 60 gallon reservoir includes a 10 micron heavy duty filter in the return line. Sight and temperature gauge is integral on the hydraulic tank face plate. Gate valves are used for servicing the hydraulic pump and/or PTO without fluid removal.

ELECTRICAL SYSTEM: 12 volt direct. All terminal strips, relays and accessory circuits are enclosed in a NEMA 12, weather resistant box, mounted externally on the pedestal. All wiring is color coded and stamped providing easy troubleshooting.

MOUNTING: Pedestal and torsion subframe are bolted directly to the chassis by eight grade 8 bolts. Requires no welding.

DESIGN/WELDING: Design conforms to ANSI B30.5. All welding conforms to AWS D1.1.

BOOM REST: Heavy duty and removable.

JLG 2250JBT

RATED LIFTING CAPACITIES

MODEL 2250JBT-RATED LIFTING CAPACITIES IN POUNDS

LOAD RADIUS FEET	BOOM LENGTH IN FEET									
	26.25	35	42	49	56	63	70	77	85	
5	45000									
8	32000									
10	28000	22000	20500	20000						
12	23000	20000	18000	17000	16500					
14	20000	17500	17000	16500	16000	15000	14000			
16	17000	16500	16000	15500	15000	14500	13500	12500		
20	13000	12750	12500	12250	12000	11500	11000	10500	9500	
25		10000	9700	9400	9100	8800	8500	8000	7500	
30		8000	7800	7600	7400	7200	7000	6800	6500	
35			6300	6100	5900	5700	5500	5300	5100	
40			5100	5000	4900	4800	4700	4500	4300	
45				4000	4000	4000	4000	3900	3800	
50					3200	3200	3200	3200	3200	
55						2600	2600	2600	2600	
60							2100	2100	2100	
65								1700	1700	
70									1300	
75										1000
80										
										775

PERMISSIBLE ROPE PULL

NUMBER PARTS LINE	9/16" DIA. 330' OF HSLR 18.5T. NOM. STRENGTH	NUMBER PARTS LINE	9/16" DIA. 330' OF HSLR 18.5T. NOM. STRENGTH
SINGLE	7500 LBS.	FOUR	30000 LBS.
TWO	15000 LBS.	FIVE	37500 LBS.
THREE	22500 LBS.	SIX	45000 LBS.

DO NOT OPERATE THIS CRANE UNLESS YOU KNOW THE DIAMETER AND TYPE ROPE CURRENTLY INSTALLED ON THE CRANE. DO NOT EXCEED PERMISSIBLE ROPE PULL OF ROPE INSTALLED ON THIS CRANE. DO NOT USE 3 PART LINE WITH BOOM LENGTH OVER 70 FEET. DO NOT USE 4 PART LINE WITH BOOM LENGTH OVER 56 FEET. DO NOT USE 5 PART LINE WITH BOOM LENGTH OVER 42 FEET. DO NOT USE 6 PART LINE WITH BOOM LENGTH OVER 35 FEET. DO NOT OPERATE THIS CRANE UNTIL YOU HAVE READ AND UNDERSTOOD "LIFTING NOTES" DECAL ON PEDESTAL.

JLG 2250JBT WITH 26 - 46 FOOT JIB

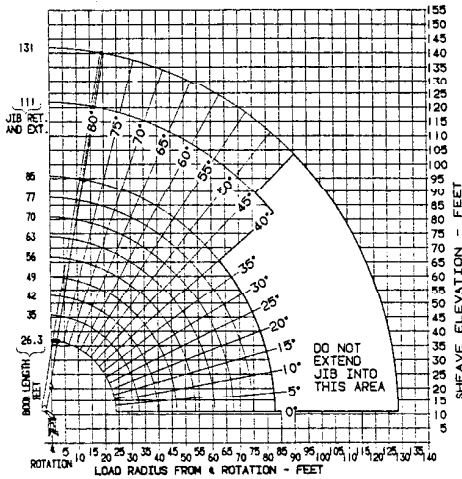

RATED JIB LIFTING CAPACITIES IN POUNDS

26-46 FT. 2 SECTION JIB				26 FT. FIXED JIB	
MINIMUM BOOM ANGLE	JIB FULLY RETRACTED	JIB FULLY EXTENDED	MINIMUM BOOM ANGLE		
80°	5000	2800	80°	4100	
75°	4400	2700	75°	4500	
70°	3400	2000	70°	3500	
65°	2700	1700	65°	2800	
60°	1900	1200	60°	2000	
55°	1400	1000	55°	1500	
50°	1050	550	50°	1150	
45°	700	375	45°	800	
40°	375		40°	475	

- CAPACITIES BASED ON ANGLE OF MAIN BOOM REGARDLESS OF BOOM LENGTH.
- RATED LIFTING CAPACITY ABOVE THE BOLD LINE IS BASED ON STRUCTURAL STRENGTH AND NOT MACHINE STABILITY. OVERLOADING THE JIB MAY CAUSE STRUCTURAL COLLAPSE OR UPSET.
- DO NOT USE JIB FOR MULTI-PART LINE OPERATIONS.
- IF ACTUAL BOOM ANGLE FALLS BETWEEN CHART VALUES LISTED, USE LIFTING CAPACITY FOR NEXT LOWER MINIMUM BOOM ANGLE.

WEIGHT REDUCTION FOR LOAD HANDLING DEVICES

HEADACHE BALL	130 LBS.
HOOK BLOCK (SINGLE SHEAVE)	220 LBS.
HOOK BLOCK (DOUBLE SHEAVE)	300 LBS.
2-SECTION JIB STOWED	100 LBS.
2-SECTION JIB ERECTED (RETRACTED)	1600 LBS.
2-SECTION JIB ERECTED (EXTENDED)	1700 LBS.
1-SECTION JIB STOWED	70 LBS.
1-SECTION JIB ERECTED	1100 LBS.

JLG 2250JBT WITH 21 FOOT OFFSET JIB

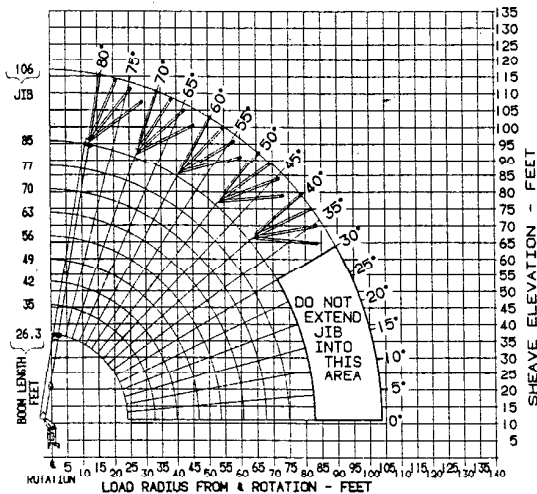

RATED JIB LIFTING CAPACITIES IN POUNDS

MINIMUM BOOM ANGLE	21 FOOT OFFSET JIB			
	JIB OFFSET 0°	JIB OFFSET 15°	JIB OFFSET 30°	JIB OFFSET 45°
80°	6000	4500	3000	2300
75°	5400	3700	2600	2100
70°	4900	3000	2300	2000
65°	4000	2500	2100	1900
60°	2200	2200	2000	1800
55°	1900	1900	1800	1600
50°	1400	1400	1400	1300
45°	1050	1000	1000	1000
40°	750	750	750	600
35°	500			
30°	350			

- CAPACITIES BASED ON ANGLE OF MAIN BOOM REGARDLESS OF BOOM LENGTH.
- RATED LIFTING CAPACITY ABOVE THE BOLD LINE IS BASED ON STRUCTURAL STRENGTH AND NOT MACHINE STABILITY. OVERLOADING THE JIB MAY CAUSE STRUCTURAL COLLAPSE OR UPSET.
- DO NOT USE JIB FOR MULTI-PART LINE OPERATIONS.
- IF ACTUAL BOOM ANGLE FALLS BETWEEN CHART VALUES LISTED, USE LIFTING CAPACITY FOR NEXT LOWER MINIMUM BOOM ANGLE.

WEIGHT REDUCTION FOR LOAD HANDLING DEVICES

OFFSET JIB STOWED	70 LBS.
OFFSET JIB ERECTED	1100 LBS.

Meets ANSI B30.5 / SAE J765

DO NOT OPERATE WITHIN 10' OF POWER LINES!!

JLG 2250JBT

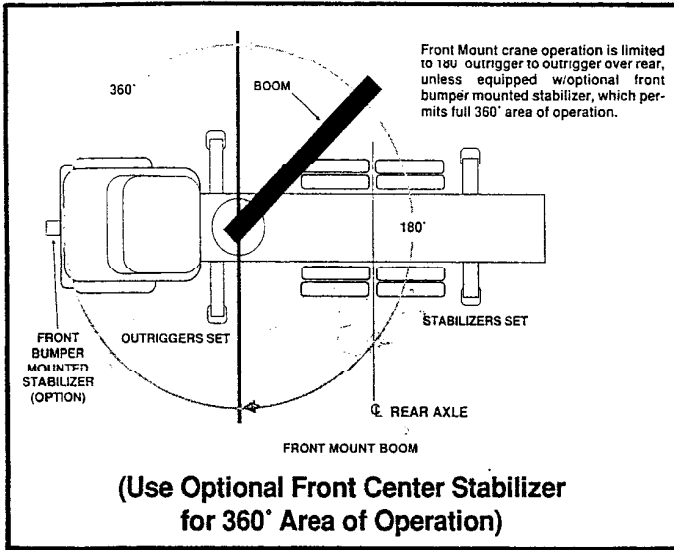

Available Options:

- 26 ft. to 65 ft. 3-Section Telescoping Boom
- Load Moment Indicating System w/Shutdown (LMI)
- Two Man Self-Leveling Platform
- Two Man Gravity Leveling Platform
- One Man Fiberglass Basket
- Two, One-Man Fiberglass Baskets
- Radio Remote Control
- Hardwire Remote Control
- 360 Degree Continuous Rotation
- Front Center Stabilizer
- Hydraulic Clam Shell
- Hydraulic Oil Cooler
- Rear Mount
- Over Frame Outriggers and Stabilizers

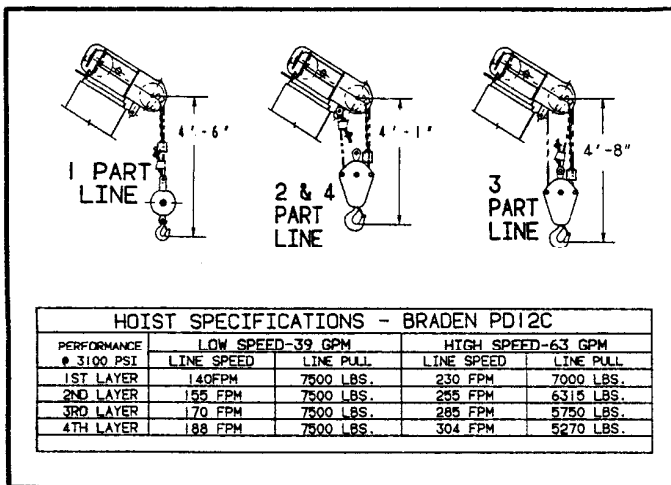

JLG INDUSTRIES, INC. MATERIAL HANDLING DIVISION

RD 6, Box 34-B
York, Pa. 17404

TEL. - (717) 792-9731 FAX. - (717) 792-4938

**MATCHING TRADITIONAL JLG
PERFORMANCE AND DURABILITY
WITH THE NEEDS OF THE OPERATOR**

WARRANTY
**A comprehensive warranty that
exceeds industry standards.**

*See your JLG Dealer to find out about our full line
of telescopic cranes and material handling products.*

DISTRIBUTED BY:

Due to continued improvements, we reserve the right to make specification and/or equipment changes without prior notification.

American Made. American Owned.